

STAGE INPUTS

- 1 Senn 912: Floor Mic SR
- 2 Senn 912: Floor Mic SRC (C if 3 total)
- 3 Senn 912: Floor Mic SLC if (purchased)
- 4 Senn 912: Floor Mic SL
- 5 Rode shotgun SR
- 6 Rode shotgun SR

ACTOR/BODY MICS

- 9 Scrooge: David Kirtemeir Countryman B3 SK 2000 EM 2050 1 1
- 10 Present: Neil Friedman Countryman B3 SK 2000 EM 2050 2 2
- 11 Marley: David Alleyt Countryman B3 SK 2000 EM 2050 2 1
- 12 Past: Katy Wolfe Zahn Countryman B3 SK 2000 EM 2050 2 2
- 13 Musician: Rachel Schlafer-Parton Countryman B3 SK 2000 EM 2050 3 1
- 14 Musician: Ted Kiterman Countryman B3 SK 2000 EM 2050 2 2
- 15 Musician: Tramell Tillman Countryman B3 SK 2000 EM 2050 4 1
- 16 Tiny Tim: E Bullard / S Tison Countryman B3 SK 2000 EM 2050 2 2
- 17 Boy Caroler: Cian Owen Bell Countryman B3 SK 2000 EM 2050 5 1
- 18 Mary Cratchit: A Payne / I Coyne Countryman B3 SK 2000 EM 2050 2 2
- 19 Belinda Cratchit: K Cimino Countryman B3 SK 2000 EM 2050 6 1
- 20 Harp Countryman B3 SK 2000 EM 2050 11 2
- 21 Guitar Countryman B3 SK 2000 EM 2050 7 1
- 22 Spare 1 Countryman B3 SK 2000 EM 2050 2 2

This computer is notw in the booth.
What inputs are best? Patched to Venue CH 45/46

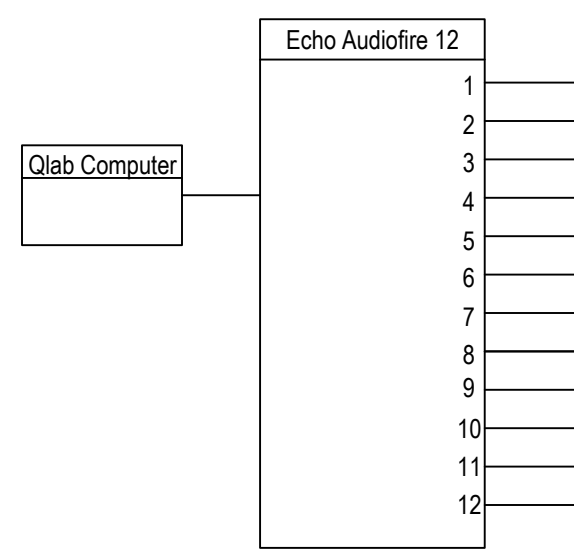
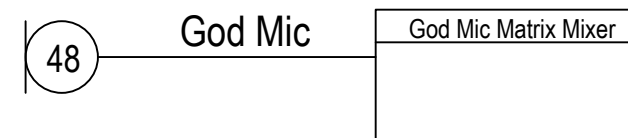
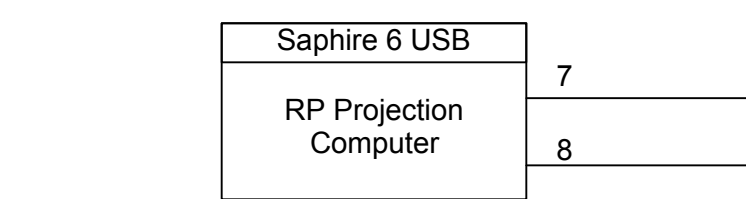

Stage Rack Inputs

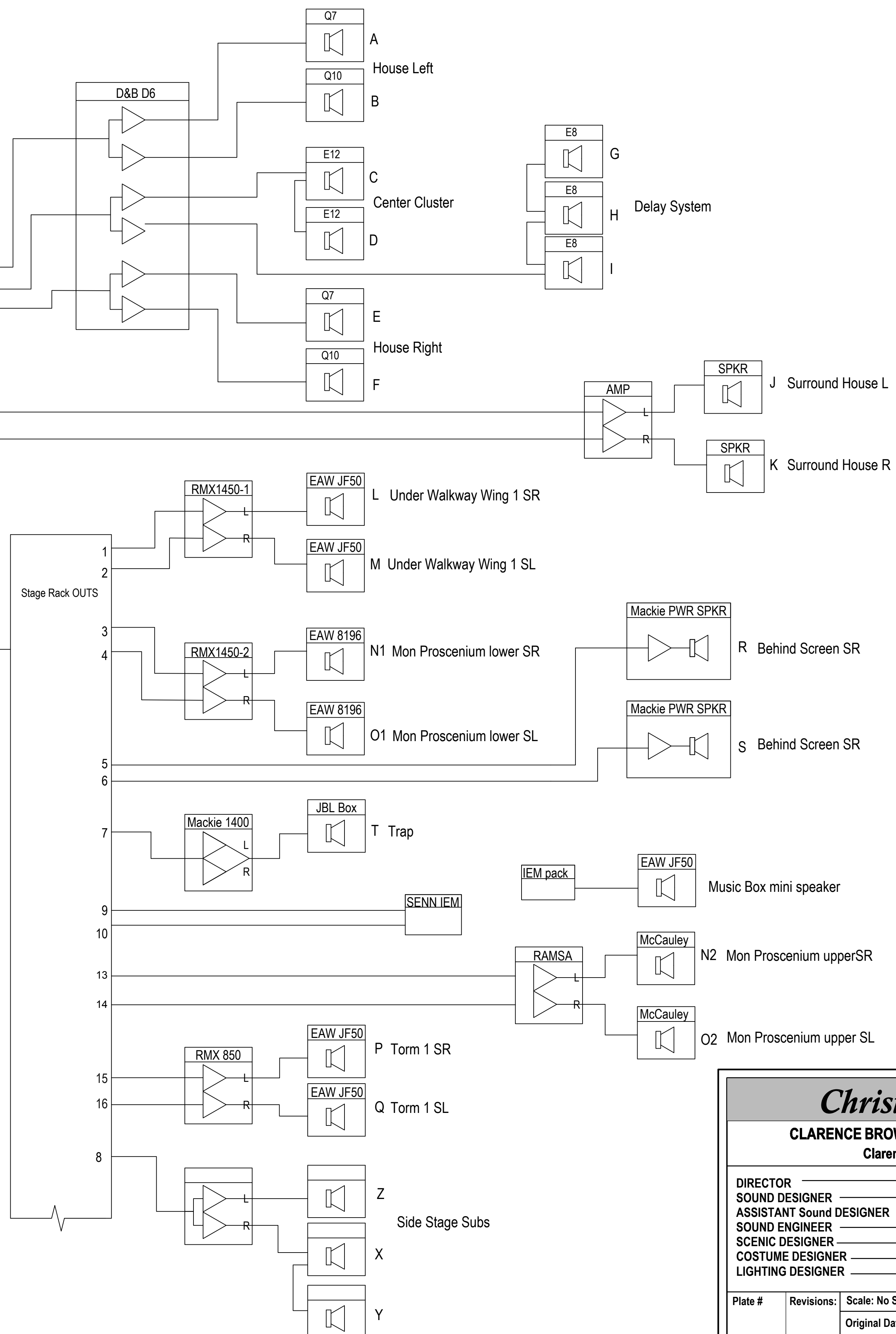
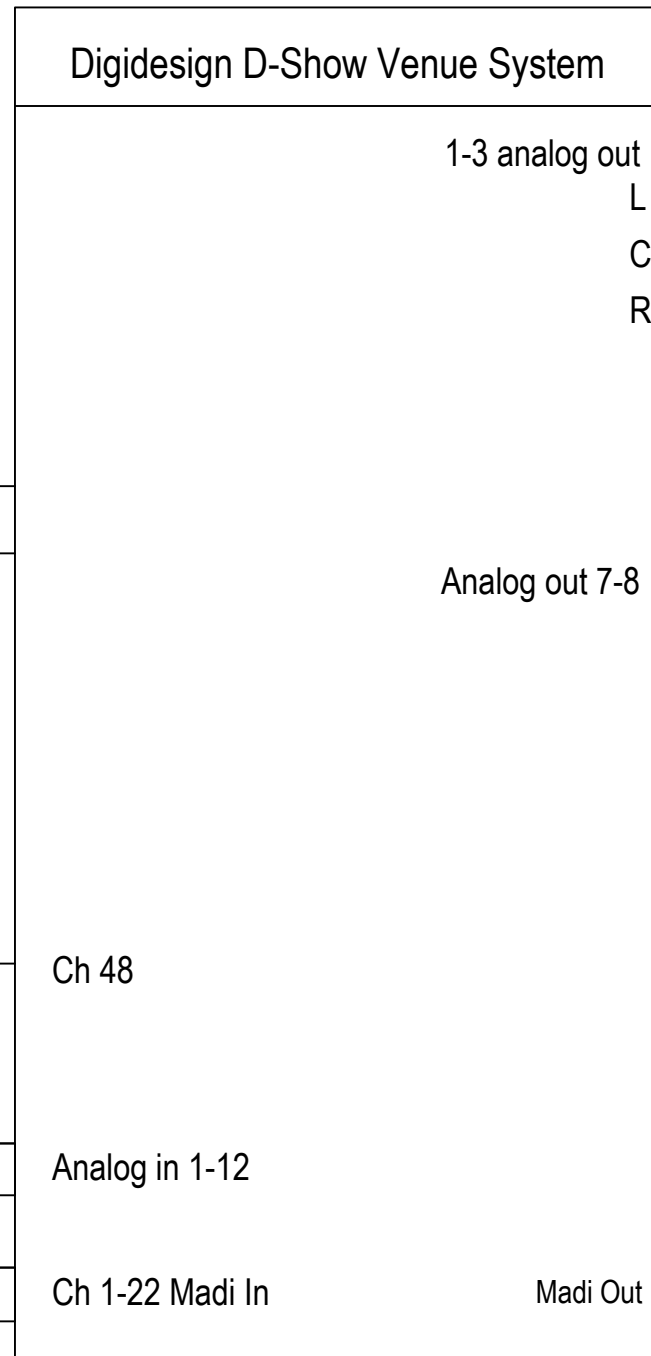

<i>Christmas Carol</i>	
CLARENCE BROWN THEATRE - Knoxville, TN	
Clarence Brown Theatre	
DIRECTOR _____	Casey Sams
SOUND DESIGNER _____	Joe Payne
ASSISTANT Sound DESIGNER _____	Isabel Tipton
SOUND ENGINEER _____	Mike Ponder
SCENIC DESIGNER _____	Chris Pickart
COSTUME DESIGNER _____	Bill Black
LIGHTING DESIGNER _____	Cat Girardi
Plate # _____	Revisions: _____
	Scale: No Scale
	Original Date: _____
	Current Draft: 10/24/13

